



AKRAPOVIC RACING SINGLE&TWIN EXHAUST SYSTEM for the SUZUKI GSX-R1300 HAYABUSA (2008)

Congratulations on purchasing an Akrapovic exhaust system. Please read these installation instructions carefully. If you have any trouble installing the system please contact your authorized dealer!

IMPORTANT INFORMATION

Exclusion of Certain Liability

1. The manufacturer, importer or dealer shall not be liable for any incidental damage including personal injury or any other damages caused by improper installation or operation of the Akrapovic exhaust system. When installing the Akrapovic exhaust system be careful that the exhaust system does not touch other parts sensitive to high temperature.
2. Akrapovic makes no representation or warranties with regard to damage caused by the improper installation, use and maintenance of the Akrapovic exhaust system. The warranty is limited to defects recognized by our technical department and to normal use, and excludes items subject to normal wear (gaskets and damping wool). The guarantee is void in case of accident, modification, improper or competition use.
3. Do not attempt to install the Akrapovic exhaust system on a motorcycle for which it was not made or tested by Akrapovic.
4. When the exhaust system gets very hot during operation, be careful not to burn yourself on the exhaust system or parts which are in direct contact with it, even when the motor is not running. Also protect other people, especially children, from the injuries mentioned above.
5. In some cases Akrapovic exhaust system kits contain chemical products (ceramic anti-seizing grease; bolt sealant). Handle with care, do not inhale or swallow. Avoid excessive contact with skin, eyes or mucous membranes. Keep out of reach of children.
6. Technical specifications of Akrapovic exhaust systems and related products subject to change without notice.

Trademarks

The Akrapovic Exhaust System Technology logo is a registered trademark of Akrapovic d.d.

Akrapovic website

Information about Akrapovic exhaust systems and related products is available on the Akrapovic website at:

<http://www.akrapovic.net/>

Copyright

No part of the Akrapovic exhaust system or its documentation may be reproduced or distributed in any form or by any means without the prior written authorization of the Akrapovic company.

© Akrapovic, d.d. All rights reserved.

Symbols

The following symbols are used throughout these installation instructions:





USE BOLT SEALANT; Apply 3 to 4 small drops of bolt sealant onto the cleaned and degreased threads before tightening bolts. **WARNING! Avoid contact with skin, eyes and mucous membranes. Do not inhale fumes. Keep out of the reach of children.**



USE ANTI-SEIZING GREASE (white tube); Prevents seizing, corrosion and excessive wear between the titanium components of your exhaust system. **WARNING! Avoid eye contact. Avoid excessive skin contact. Keep out of the reach of children.**



USE ANTI-SEIZE LEAD-FREE COPPER PASTE (black tube); Provides trouble-free and long-lasting protection against seizing, corrosion and rusting of bolts, threaded ends, nuts, joints, etc. Also protects against vibration, wear and impact. **WARNING! Avoid eye contact. Avoid excessive skin contact. Keep out of the reach of children.**

INSTALLATION INSTRUCTIONS

 **BEFORE INSTALLING CHECK SCHEMATIC OF THE EXHAUST SYSTEM!**

! IF ANY ITEMS IN THE AKRAPOVIC EXHAUST SYSTEM PACKAGE ARE MISSING PLEASE CONTACT YOUR AUTHORIZED DEALER. KEEP THE SCHEMATIC FOR FUTURE REFERENCE.

! THESE INSTALLATION INSTRUCTIONS MUST BE READ CAREFULLY IN ORDER TO ENSURE PROPER INSTALLATION AND OPERATION OF THE AKRAPOVIC EXHAUST SYSTEM.

! THE EXHAUST SYSTEM CAN BE EXTREMELY HOT. ALLOW THE MOTORCYCLE TO COOL DOWN BEFORE BEGINNING INSTALLATION.

 **WE ADVISE YOU TO LEAVE INSTALLATION TO A QUALIFIED SERVICEMAN. IMPROPER INSTALLATION MAY RESULT IN A SHORTER LIFETIME OF THE EXHAUST SYSTEM AND/OR DAMAGE TO THE MOTORCYCLE.**



T-handle 10mm wrench
T-handle 12mm wrench
T-handle 10mm swiveling wrench
T-handle 4mm three hexagon key wrench
T-handle 5mm three hexagon key wrench
T-handle 6mm three hexagon swiveling key wrench
Combination 12mm wrench
Combination 17mm wrench
Spring puller
Small flat screwdriver

REMOVAL OF STOCK EXHAUST SYSTEM:

1. Put the motorcycle on a side stand, we recommend a racing stand. Make sure, that surface is solid and flat.
2. Remove the bolt and plastic fasteners from the lower part of the cowling (**Figure 1, 2, 3**).



Figure 1



Figure 2



Figure 3

3. Untighten the bolts from the metal clamps at the mufflers - link pipes joints (**Figure 4**). Unscrew the bolts from the muffler chassis hanging brackets (**Figure 5**). Remove the mufflers and the gaskets (**Figure 6, 7, 8**).



Figure 4



Figure 5



Figure 6



Figure 7



Figure 8

4. Remove the bolts and plastic fasteners from the left and right side of the cowling and remove the cowling (Figure 9, 10, 11, 12, 13, 14, 15, 16, 17, 18, 19, 20, 21, 22, 23).



Figure 9



Figure 10



Figure 11



Figure 12



Figure 13



Figure 14



Figure 15

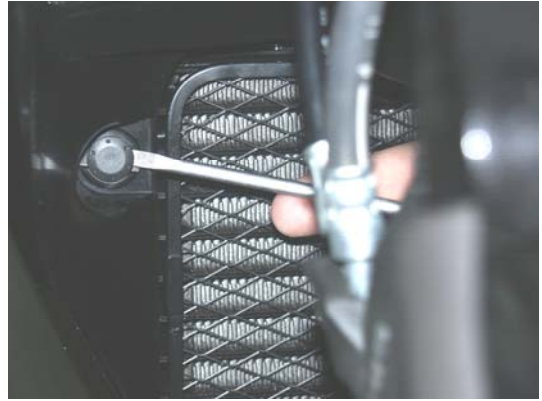

Figure 16



Figure 17



Figure 18

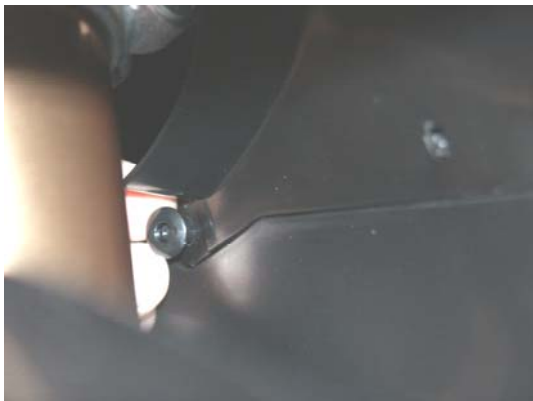

Figure 19



Figure 20



Figure 21



Figure 22



Figure 23

5. Unscrew the bolt of the water cooler bracket (Figure 24). Unscrew the bolts from the lower oil cooler hanging bracket and remove the bracket (Figure 25, 26, 27). Slightly remove the cooler. **WARNING! do not disconnect the cooling system tubes!** Make sure not to damage the cooling fins.



Figure 24



Figure 25



Figure 26



Figure 27

6. Unscrew and remove the lambda sensor (Figure 28, 29).



Figure 28



Figure 29

7. Unscrew the bolts from the header tube flanges; make sure not to damage the cooling fins (Figure 30). Unscrew the bolt from chassis hanging bracket of stock headers (Figure 31) and remove the stock header tubes (Figure 32). Unscrew and remove the chassis hanging bracket of stock headers (Figure 33, 34). For Racing twin exhaust only: replace the stock chassis hanging bracket of stock headers with special Akrapovic bracket (tightening torque 22Nm/16ftlb).



Figure 30



Figure 31



Figure 32



Figure 33



Figure 34

INSTALLATION OF THE AKRAPOVIC RACING SINGLE & TWIN EXHAUST SYSTEM:

1. Set up the sleeves together with the flanges and springs; make sure they are correctly oriented (Figure 35, 36). Hand tighten the flanges make sure not to damage the cooling fins.



Figure 35



Figure 36

2. For easier mounting put headers together; make sure they are correctly oriented (Figure 37, 38, 39, 40). Insert the header tubes properly, attach the springs and tighten the flanges; **WARNING!** make sure, that springs pull the headers all the way into the sleeves – use rubber mallet if necessary to tap the connections into place! make sure not to damage the cooling fins (Figure 41, 42). Reattach the oil cooler bracket and reattach the coolers (Figure 43, 44, 45, 46).



Figure 37



Figure 38



Figure 39



Figure 40



Figure 41



Figure 42



Figure 43

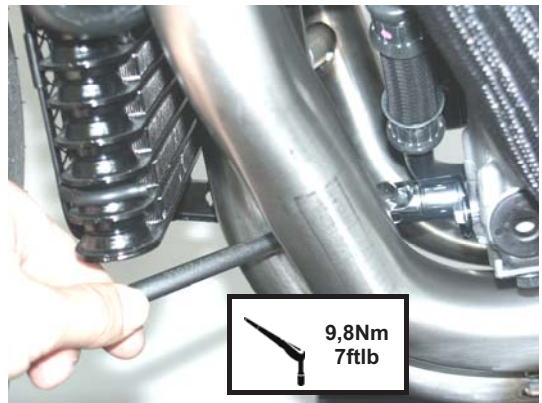

Figure 44

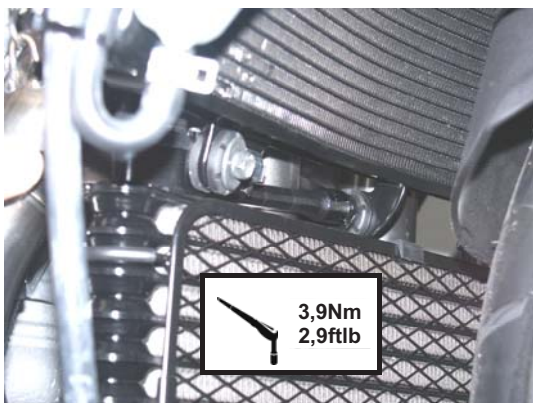

Figure 45

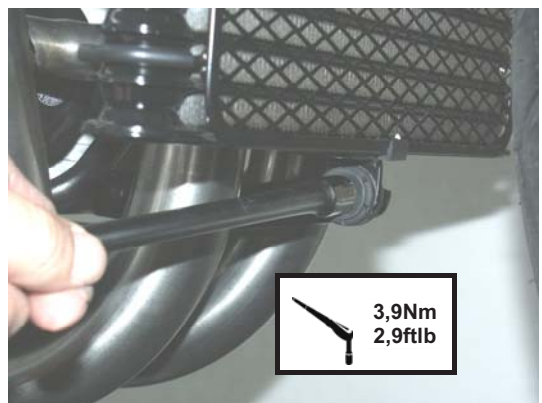

Figure 46

- Slide the collectors onto the header tubes and attach the springs **WARNING!** make sure, that springs pull the collectors all the way onto the headers – use rubber mallet if necessary to tap the connections into place! (Figure 47, 48).



Figure 47



Figure 48

- For Racing single exhaust only: slide the link pipe onto the collectors and attach the springs **WARNING!** make sure, that springs pull the link pipe all the way onto the collectors – use rubber mallet if necessary to tap the connections into place! (Figure 49, 50). Tighten the lambda sensor; make sure not to damage the sensor's electrical lead (Figure 51, 52). **WARNING:** grease only the threads of the lambda sensor!



Figure 49



Figure 50

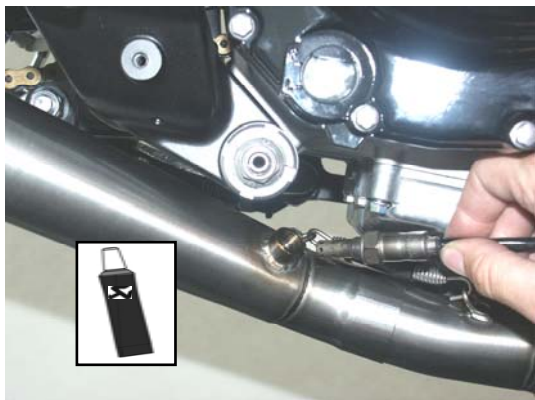

Figure 51

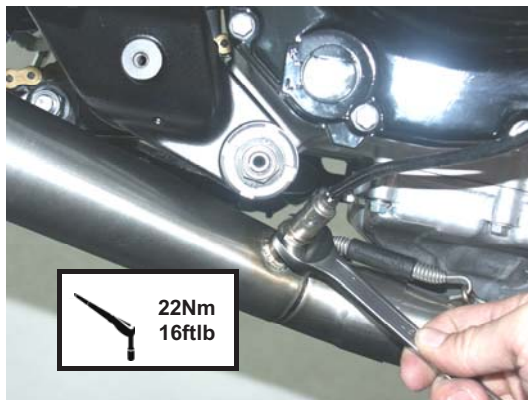

Figure 52

5. **For Racing twin exhaust only:** slide the twin ink pipe/collector onto the collectors and attach the springs **WARNING!** make sure, that springs pull the link pipe all the way onto the collectors – use rubber mallet if necessary to tap the connections into place! Tighten the twin ink pipe/collector onto the bracket (tightening torque 22Nm/16ftlb).

6. Correctly position the carbon-fiber clamp(s) and slide it onto the muffler - **For Racing single exhaust only:** bear in mind the **left offset** of the carbon-fiber clamp viewed from the rear. **For Racing twin exhaust only:** bear in mind the **left offset** of the carbon-fiber clamp viewed from the rear for the **right side muffler** and the **right offset** of the carbon-fiber clamp viewed from the rear for the **left side muffler**. **!WARNING:** open the clamp(s) slightly wider than the diameter of the outer sleeve(s) of the muffler – do not scrape it along the muffler outer sleeve! (Figure 53). Position the muffler(s) correctly and slide it onto the outlet side of the link pipe(s), hand tighten the muffler clamp(s) to the bracket(s) and attach the springs **WARNING!** make sure, that springs pull the muffler(s) all the way onto the link pipe – use rubber mallet if necessary to tap the connections into place! (Figure 54, 55, 56, 57).



Figure 53



Figure 54



Figure 55



Figure 56



Figure 57

7. Tighten the bolt(s) on the carbon-fiber clamp(s)/stock muffler bracket joint(s) (**Figure 58**). Make sure the link pipe or muffler is not touching the frame or any other part of the motorcycle. **For Racing single exhaust only:** remove the metal collar from the left muffler bracket (**Figure 59, 60**). Attach the cowlings in the reverse order from the order in which they were removed (**Figure 61**).

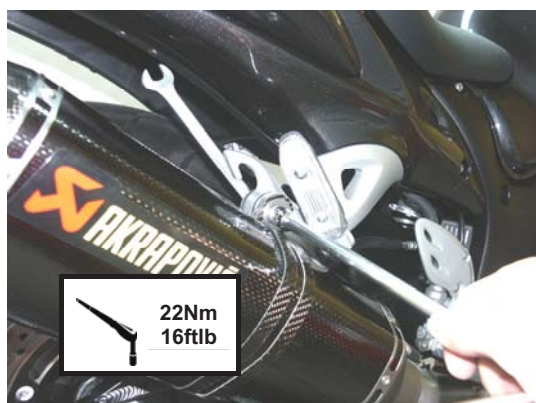

Figure 58



Figure 59



Figure 60

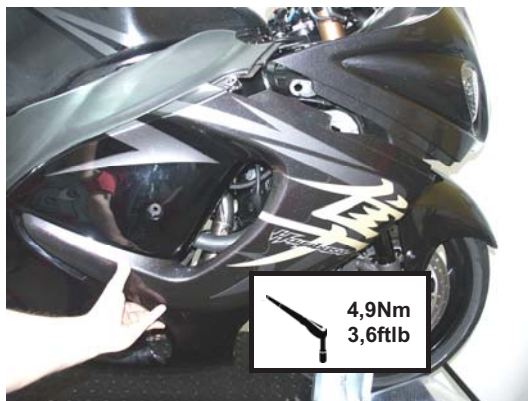

Figure 61

Final installation:

1. Clean grease spots:
 - a. Muffler – carbon-fiber outer sleeve: use a soft dry cloth.
 - b. Muffler – titanium outer sleeve: use a soft cloth sprayed with a multi-purpose spray lubricant (WD-40 or equivalent).
 - c. Muffler – carbon-fiber outlet cap: use a soft dry cloth.
 - d. Stainless steel link pipe: use a soft cloth sprayed with a contact cleaner, then wipe with a soft dry cloth.

Cleaning will prevent spots from burning onto the surface. Do not use aggressive chemical cleaners, because they can damage the sticker.

Position of the correctly installed Akrapovic **RACING SINGLE** (Figure 62) and **RACING TWIN** (Figure 63) systems.



Figure 62



Figure 63

2. Check the operation of the brakes and suspension. Make sure all the bolts are sufficiently tightened. In case the exhaust system touches the cowling or other parts repeat the adjustment of the exhaust system or contact your authorized dealer.

! IT IS NORMAL IF WHITE SMOKE COMES OUT OF THE MUFFLER ON FIRST OPERATION.

! DO NOT STAND BEHIND THE MUFFLER ON FIRST OPERATION.

! DO NOT USE AUTOMOTIVE WHEEL CLEANERS OR ANY CLEANING PRODUCTS WHICH CONTAIN ACIDIC ADDITIVES TO CLEAN AKRAPOVIC EXHAUST SYSTEMS.

MAINTENANCE OF THE AKRAPOVIC EXHAUST SYSTEM

1. Clean the titanium exhaust components with a multi-purpose spray lubricant (WD-40 or equivalent), carbon fiber exhaust components with soft and dry cloth and stainless steel components with soft cloth sprayed with contact cleaner, then wipe with soft and dry cloth. Do not use aggressive chemical cleaners, because they can damage the sticker. A change in the color of the exhaust system is normal due to the high temperatures.
2. The wearing out of the muffler silencing material depends on the type of the engine and riding style. Contact your dealer/serviceman if visible changes appear on muffler's outer sleeve or the noise level is increased.
3. Periodically make sure all the bolts and springs are sufficiently tight.

SUZUKI GSX-R 1300 (Hayabusa) / Complete exhaust system / RACING LINE1, model year: 2008, SINGLE
Product code: S-S13R2-RC
S-S13R2-RT

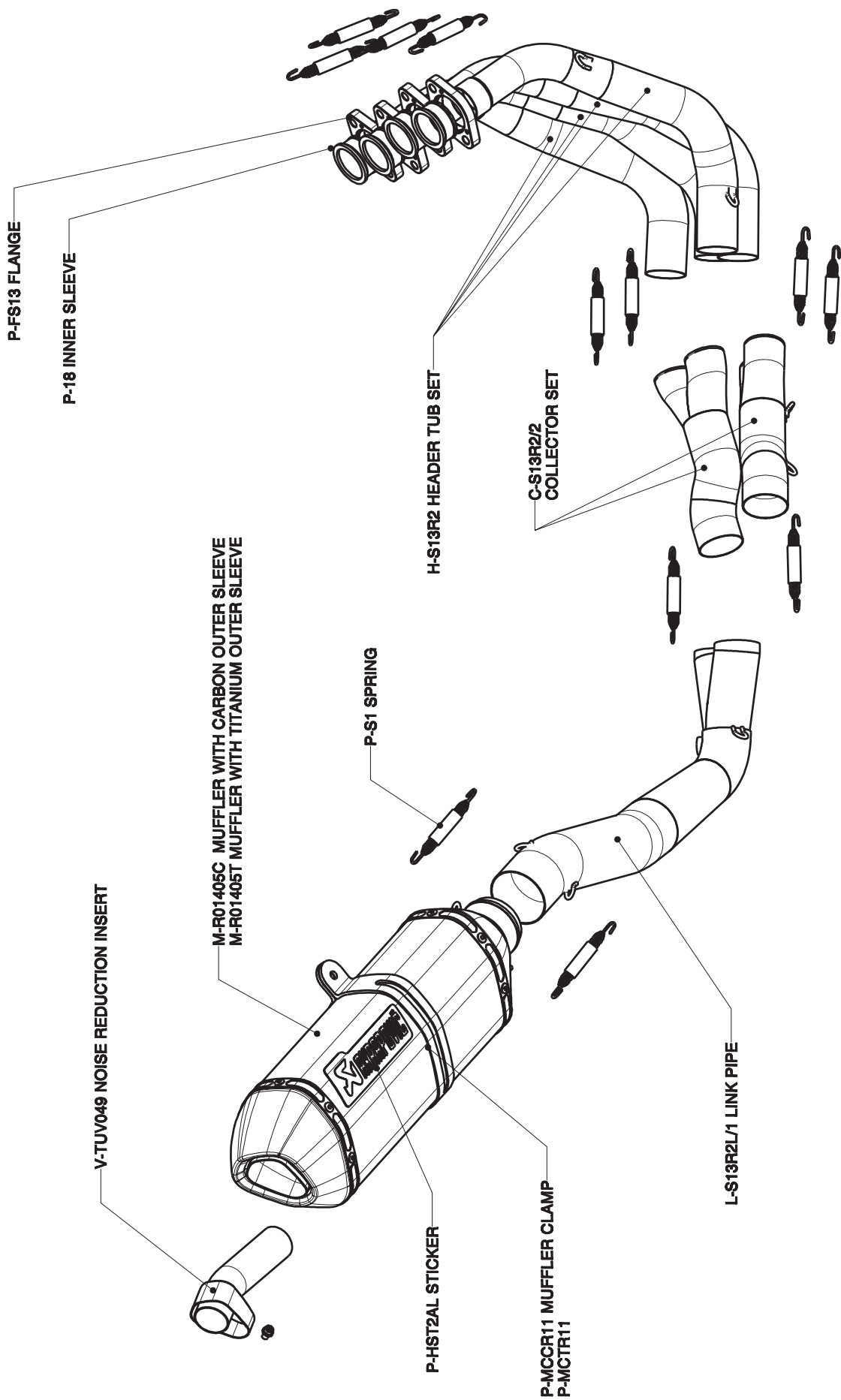

P-FS13 FLANGE

P-18 INNER SLEEVE

H-S13R2 HEADER TUB SET

C-S13R2/2 COLLECTOR SET

M-R01405C MUFFLER WITH CARBON OUTER SLEEVE
M-R01405T MUFFLER WITH TITANIUM OUTER SLEEVE

P-S1 SPRING

V-TUV049 NOISE REDUCTION INSERT

P-HST2AL STICKER

P-MCCR11 MUFFLER CLAMP
P-MCTR11

L-S13R2L/1 LINK PIPE

SUZUKI GSX-R1300 (Hayabusa) Complete exhaust system/RACING LINE/TWIN; model year: 2008
Product code:S-S13R2-RC/1
S-S13R2-RT/1

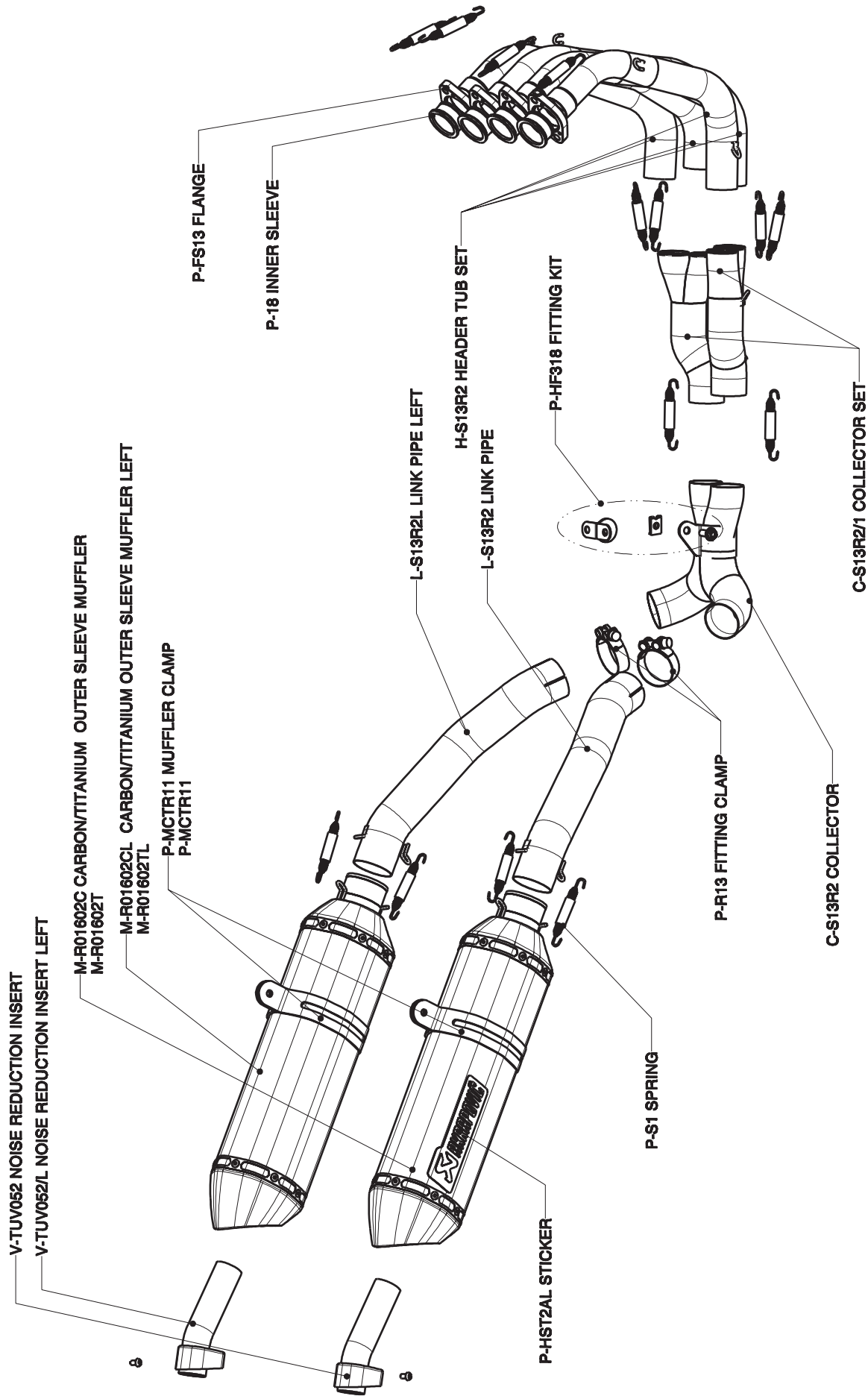

SUZUKI GSX-R1300 (Hayabusa) Complete exhaust system/Racing pipes with street legal SO mufflers, TWIN
model year: 2008
Product code: S-S13R2-HRC/1
S-S13R2-HRT/1

WARNING! IN CASE OF COMBINATION WITH RACING TUBE SET THE SLIP-ON HOMOLOGATION IS NOT VALID!

